

# 103060LI

## Gullies - concave grating D400

BENOR   hinged



### DESCRIPTION

Gullies for road infrastructure, industrial zones D400

### ADVANTAGE PRODUCT

- Hinged grating (opening direction can be changed)
- Concave grating, with round bars or 45° bars
- Lateral outlet Ø PVC 160
- 2 handling hooks
- Grating supports on 6 points with EPDM seal.

### MATERIAL

Ductile iron GJS 500-7 depending on EN1563

### CERTIFICATION THIRD PARTY

Conform PTV 802, type F1 class D400  
Certified EN124-2 BENOR by Copro

### PLACE OF INSTALLATION

Group 3, →see EN124-1

For gully tops installed in the area of kerbside channels of roads which when measured from the kerb edge, extend a maximum of 0,5m into carriageway.

### Confirmation about concave gratings:

EN124-2 is not applicable for concave gratings installed onto roads. These gratings need to be installed in areas of kerbside channels along roads

### OPTIONS

- Available with flat grating: 103060LP

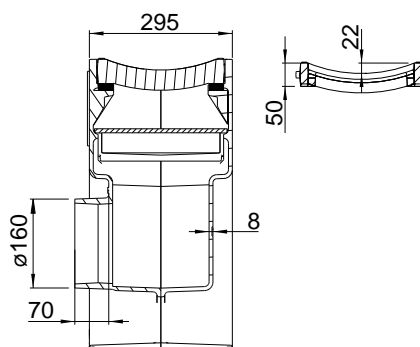
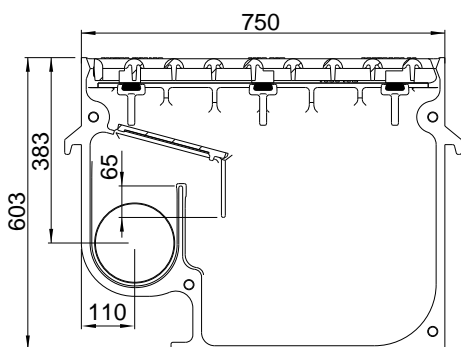
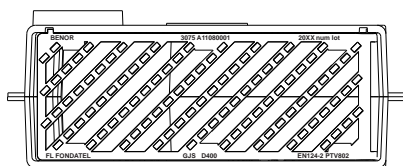
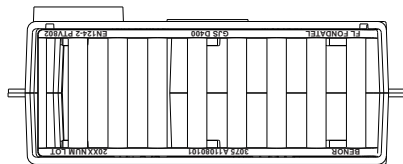

REFERENCE	ART. N°	KG	CAPACITY	CAPACITY HOLDING TANK	PACK.
AVA 307560 concave - round bars - lat - pvc	103060LI0.160	126,0	18 dm <sup>2</sup>	46L	8
AVA 307560 concave - 45° bars - lat - pvc	103060LI7.160	126,0	18 dm <sup>2</sup>	46L	8

The validity of the data sheet can be verified on the COPRO website ([www.copro.eu](http://www.copro.eu))

Sizes in mm - Weights, sizes and sketch are indicative - Uncontrolled distribution.