

E3 Gate valve | Combi valves



Overview

Design features

- Resilient seated gate valve according to EN 1171, EN 1074-1 and EN 1074-2 with smooth, straight-through bore
- Double bayonet O-ring carrier is connecting the spindle to the bonnet, allowing a fully encased, uniform epoxy powder coated bonnet for further improved corrosion protection
- Wedge guide made of wear resistant POM material in load optimized design minimizes attrition and ensures lowest torque actuation
- Wedge is flexible and fully linked in vulcanized elastomer to the wedge nut. This snug fit dampens vibration during opening and closing of the wedge
- Wedge nut has a long thread length allowing significantly higher torques than the standard before breaking
- O-rings, lip-seals mounted in the bonnet are replaceable under operating pressure
- Extended edge protection to avoid damages during transport, storage and assembly
- Sliding disks and ball bearing assure low friction performance of the spindle
- 100% suitable for buried installations

Material | Technical features

- 1,2 Body (1), bonnet (2), centering flange (16) made of ductile iron, epoxy powder coated inside and out
- 3 Wedge made of ductile iron (DN 50 made of dezincification-resistant brass) with vulcanized elastomer all-over
- 4 Wedge guide made of wear-resistant plastic
- 5 Wedge nut made of dezincification-resistant brass
- 6 Duplex stainless steel spindle with rolled thread and flat-rolled anti-friction surface
- 7 O-ring carrier made of brass, DN 50 – 200 with double bayonet
- 8 O-rings made of elastomer
- 9 Wiper ring made of PE
- 10 Bonnet gasket made of elastomer
- 11 Allen screws made of stainless steel, encased into the body with interlacing gasket and sealing compounds, ensuring full corrosion protection
- 12 Extended edge protection made of PE
- 13 Spindle bearing made of dezincification resistant brass
- 14 Sliding disks made of POM
- 15 Safety screw made of stainless steel
- 17 Centering flange gasket made of elastomer
- 18 Axial ball bearing permanently lubricated
- 19 Centering ring made of POM
- 20 Lip seals made of elastomer
- 21 Wiper ring made of elastomer

DN 50 – 200

Spindle bearing with sliding disks

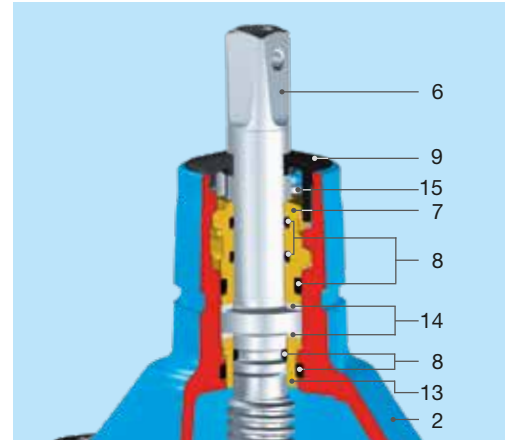

DN 250 – 400 Spindle bearing with ball bearing and additional sliding disks

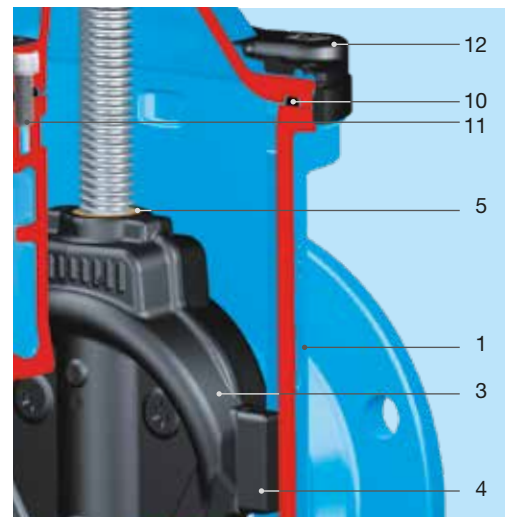
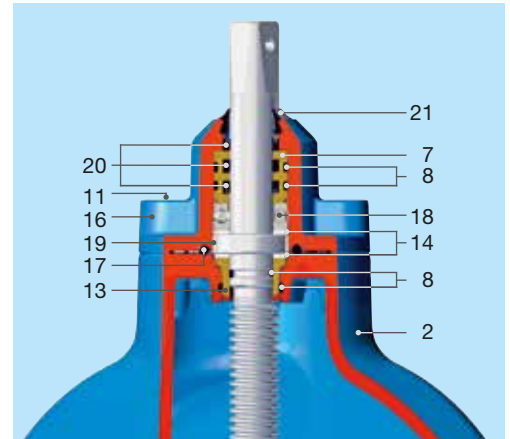

DN 500 – 600 in preparation -
currently available - see page A 11/3

E3 Combi-III

Flanged T-piece with 3 flanged outlets and 2 or 3 integral E3 valves, PN 10 | PN 16

Design features

- Resilient seated gate valve combined with flange-T-piece
- Space saving installation through short design as well as savings in material, work, transport and storage costs
- The compact design enables the valve chamber to be made from sectional concrete giving typical savings of 25 % in chamber construction costs
- Vertical connection DN 100 optional
- Internal thread connection 3/4" - optional for manometer, ball valve outlet etc.
- Flanges sized in accordance with EN 1092-2, drilled according EN 1092-2 | PN 10 standard; EN 1092-2 | PN 16 DN 200 please specify on order - other standards on request
- Suitable for cleaning with a cleaning pig
- Duplex stainless steel spindle

No. 4450E3

No. 4460E3



Suitable accessories

Suitable accessories: see page A 2/2

Handwheel:		No. 7800
Extension spindles:	rigid	No. 9000E2/E3
	telescopic	No. 9500E2/E3
Surface box:		No. 4550
Operating cap:		No. 2156, No. 2157
Extension spindle:		No. 7820, No. 7825
Position indicator:		No. 2170E2/E3
Bolts:		No. 8810, No. 8830, No. 8840
Flat gasket:		No. 3390, No. 3470
Blanking cap:		No. 8570E2/E3

Instead of a bonnet, a cap No. 8570E2/E3 can be fitted onto the body of any outlet not requiring a valve



Please specify the arrangement of the valves in a clockwise direction!

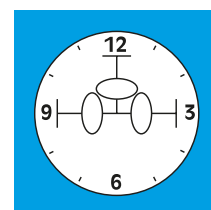

Order no.	Version	MOP (PN)	No. of valves	Dimensions/DN				
				80	100	125	150	200
4450E3	Without vertical centre outlet	16	2					
			3					
4460E3	With vertical outlet		2					
			3					

E3 Combi-III

Flanged T-piece with 3 flanged outlets and 2 or 3 integral E3 valves, PN 10 | PN 16

No. 4450E3

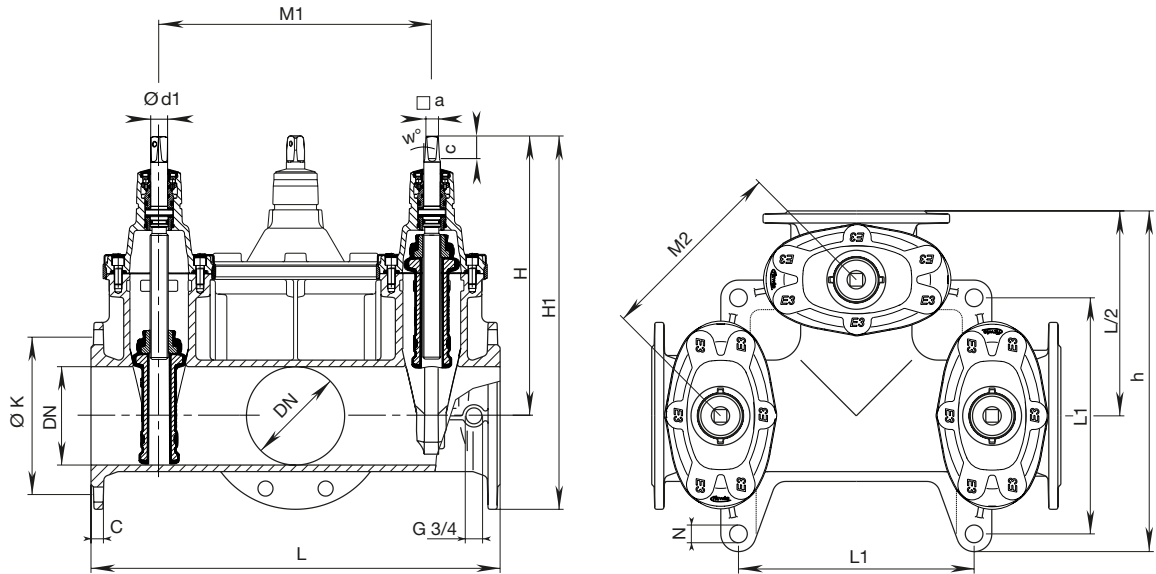

DN	E3 Combi III without vertical centre outlet										Spindle			Weight (no. of valves)		
	L	H	H 1	ØK	C	M1	M2	L1	h	N	□ a	c	w°	Ød1	2	3
80	435	313	413	160	19	255	180	-	318	-	17,3	33,8		24	45,0	47,0
100	555	343	453	180	19	365	258	212	411	27	19,3	37,2		24	68,0	67,0
125	615	421	571	210	19	415	294	360	515	27	19,3	34,9	3°	26	101,0	153,0
150	625	433	576	240	19	415	294	360	520	27	19,3	34,9		26	105,0	114,5
200	695	541	711	295	20	465	329	445	602	32	24,3	48		30	167,0	183,0

No. 4460E3

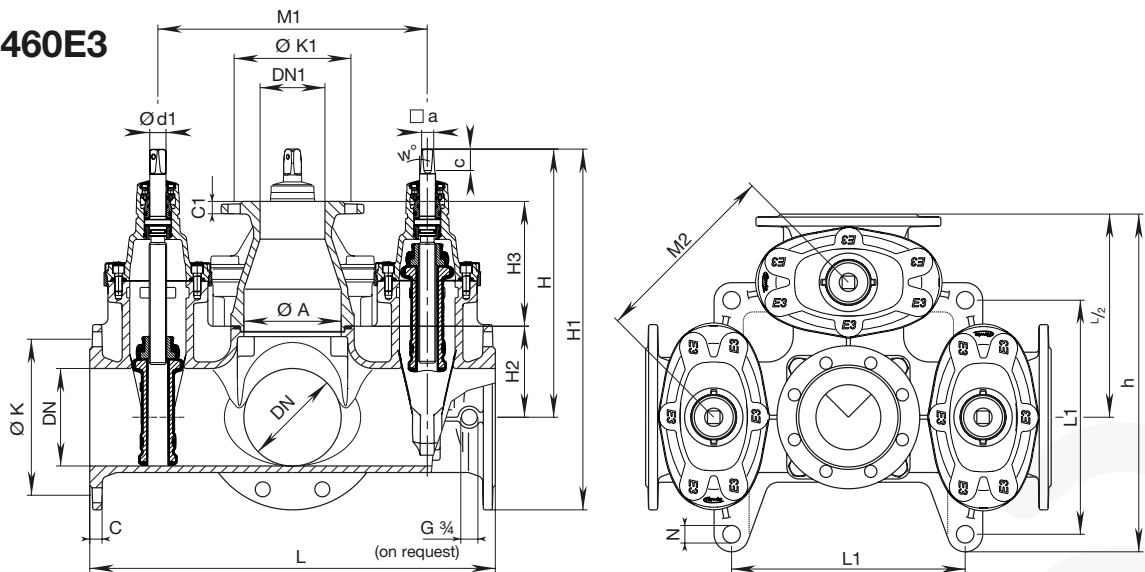

DN	E3 Combi III with vertical centre outlet													Spindle			E3 Combi III with vertical centre outlet					
	ØA	DN 1	L	L1	H	H1	H2	H3	C	C1	ØK	ØK1	M1	M2	h	N	□ a	c	w°	Ød1	2	3
100	100	100	555	212	343	453	90	+	19	+	180	+	365	258	411	27	19,3	37,2		24	71,0	76,0
150	150	100	625	360	433	576	140	192	19	19	240	180	415	293,5	520	27	19,3	34,9	3°	26	120,0	130,0
200	200	100	695	445	541	711	180	192	20	19	295	180	465	329	602	32	24,3	48		30	198,0	205,0

+ flange connection directly on the body - stud