

RepLINK - Manchon de réparation fonte

Version 1



Version 2



Pour tuyaux acier, fonte, PVC/PE et fibre-ciment, avec une très large tolérance.

Mise en œuvre facile, avec déviation angulaire de $\pm 3^\circ$.

Encombrement et masses

Version 1

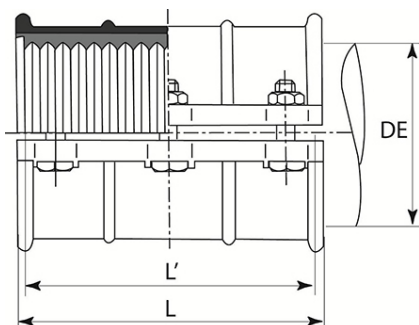

Version 2

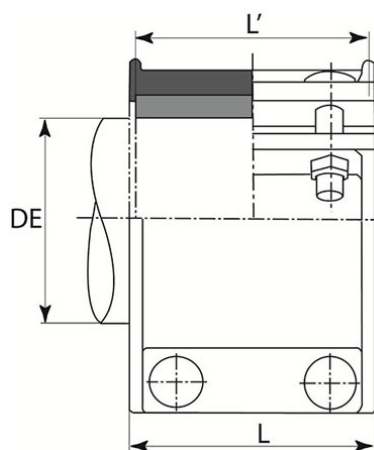

DN	Ø DE mini	Ø DE Maxi	PFA	L	Désignation	Masse	Référence
mm	mm	mm	bar	mm	Type	kg	
40	44	52	16	200	W2-0 / Version 1	6.0	MRA40SAC0
40	54	61	16	200	W2-A / Version 1	5.7	MRA40SACA
50	60	68	16	200	W2-B / Version 1	5.9	MRA50SACB
60/65	76	87	16	240	W2-C / Version 1	8.3	MRA60SACC
80	89	98	16	200	W2-D / Version 1	8.6	MRA80SACD
80	95	108	16	200	W2-F / Version 1	8.4	MRA80SACF
100	108	118	16	240	W2-G / Version 1	11.6	MRB10SACG
100	116	128	16	240	W2-I / Version 1	11.2	MRB10SACY
125	133	144	16	245	W2-J / Version 1	13.8	MRB12SACJ
125	142	150	16	245	W2-L / Version 1	13.7	MRB12SACL
150	159	172	16	300	W2-M / Version 1	21.3	MRB15SACM
150	168	184	16	300	W2-P / Version 1	22.3	MRB15SACP

DN	Ø DE mini	Ø DE Maxi	PFA	L	Désignation	Masse	Référence
mm	mm	mm	bar	mm	Type	kg	
175	193	203	16	400	W2-Q / Version 1	39.9	MRB17SACQ
200	214	225	16	400	W2-R / Version 1	37.5	MRB20SACR
200	216	244	10	260	W3-H / Version 2	25.5	MRB20SACH
250	267	274	16	460	W2-S / Version 1	42.5	MRB25SACS
250	267	298	10	355	W3-I / Version 2	47.5	MRB25SACY
275	290	303	16	460	W2-T / Version 1	54.5	Nous consulter
300	315	326	16	500	W2-U / Version 1	73.0	MRB30SACU
300	315	358	10	400	W3-J / Version 2	60.7	MRB30SACJ
300	334	338	16	500	W2-V / Version 1	70.0	Nous consulter
300	340	352	16	500	W2-Y / Version 1	72.5	Nous consulter
350	368	400	10	505	W3-K / Version 2	85.0	MRB35SACK
400	400	429	10	505	W3-N / Version 2	89.0	MRB40SACN
400	444	466	10	505	W3-W / Version 2	114.0	MRB40SACW

Matériaux et revêtements

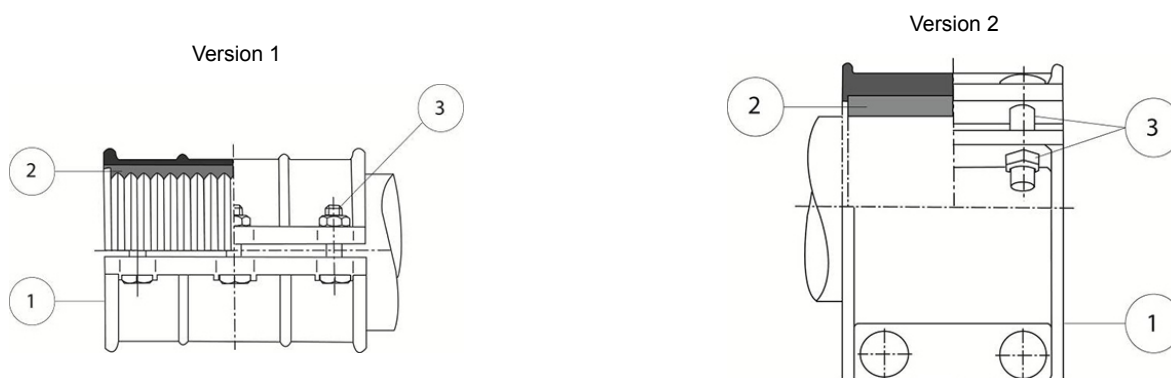

Item	Désignation	Nombre	Matériaux	Normes
1	Corps	2 parties pour version 1 3 parties pour version 2	Fonte GS/EN-GJS-400-15	NF EN 1563
2	Joint	1	NBR	ISO 4633
3	Boulonnerie (*)	s/DN	Acier galvanisé à chaud classe 8.8	ISO 8677

(*) Boulonnerie inox revêtue PTFE sur demande